

REV.	CHANGGE DESCRIPTION	DATE
A	New Issue	2023-5-2

1. MECHANICAL DIMENSIONS :

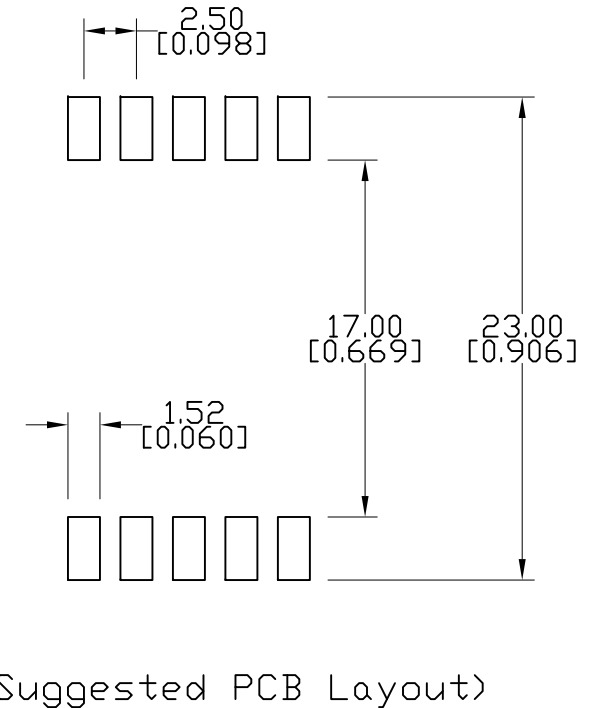
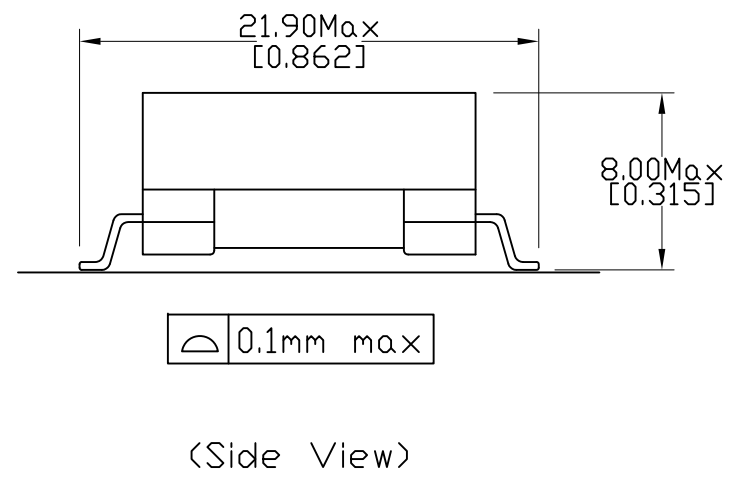
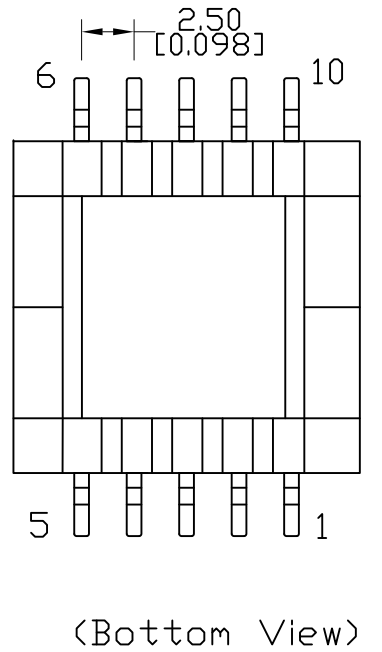
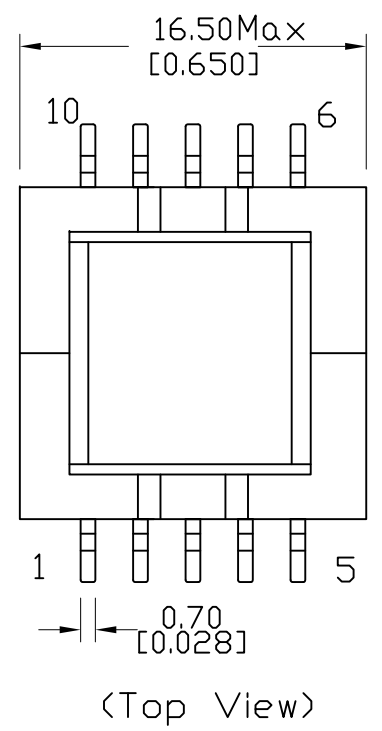

RoHS Compliant

NOTE.DIMENSIONS : MM(INCHES)/ UNLESS OTHERWISE SPECIFIED ALL TOLERANCES ARE ±0.5(0.020).

	A4 SIZE	TAG PART NO.:	VENDOR PART NO.:		Drawn:	Zhang Xue
		1SFD1501F			Designed:	Yang Tian
<small>THESE DRAWINGS AND SPECIFICATIONS ARE THE PROPERTY OF TAG TECHNOLOGY CO., LTD. AND SHALL NOT BE REPRODUCED OR USED AS THE BASIS FOR THE MANUFACTURE OR SELL OF APPARATUSES OR DEVICES WITHOUT PERMISSION.</small>	 THIRD ANGLE PROJECTION	DESCRIPTION:	UNIT	USED ON	Approved:	Deane
		XFMR, FLYBACK, 5V@4.8A, 1500V ISOLATION	mm[inch]		Date:	2023-5-2
		SHEET	1 OF 2	REV.	A	

2. SCHEMATIC:

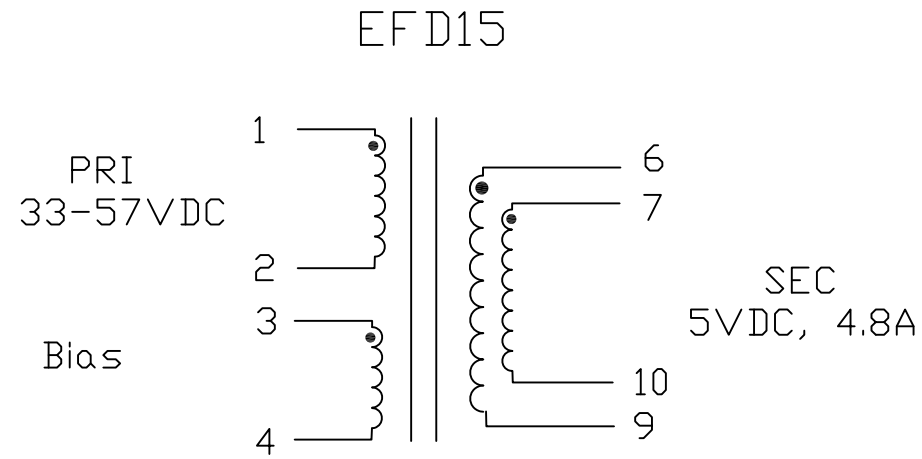

4.WINDING:

ORDER	S--F	WIRE	TURN	TAPE 9mm
PRI	1-2	2UEW-F ϕ 0.35mm	32	1
BLAS	4-5	2UEW-F ϕ 0.2mm	17	1
SEC	6,7-9,10	2UEW-F ϕ 0.35mm*4P	8	2

3. ELLECTRICAL TES CHARACTERISTICS :

Testing Ite	VALUE	PIN Numbers
INDUCTANCE @250KHZ, 0.1V	95uH \pm 5%	1-2
LEAKAGE INDUCTANCE @250KHz,0.1V	0.88uH MAX	1-2 (short4,5,6,7,9,10)
DC RESISTANCE @20°C	144m Ω MAX	1-2
	298m Ω MAX	4-5
	18m Ω MAX	6,7-9,10
URNS RATIO	1:0.53:0.25 \pm 3%	(1-2):(4-5):(6,7-9,10)
HI-POT TEST	1500VAC,1mA,60S	PRI-SEC , BIAS-CORE

RoHS Compliant

TAG ECO TECH CO., LTD.

A4
SIZE

TAG PART NO.:
1SFD1501F

VENDOR PART NO.:

Drawn: Zhang Xue

Designed: Yang Tian

Approved: Deane

Date: 2023-5-2

THESE DRAWINGS AND SPECIFICATIONS ARE THE PROPERTY OF TAG TECHNOLOGY CO., LTD. AND SHALL NOT BE REPRODUCED OR USED AS THE BASIS FOR THE MANUFACTURE OR SELL OF APPARATUSES OR DEVICES WITHOUT PERMISSION.

THIRD ANGLE
PROJECTION

DESCRIPTION:
XFMR, FLYBACK, 5V@4.8A,
1500V ISOLATION

UNIT mm[inch] USED ON

SHEET 2 OF 2

REV. A