

REV.	CHANGGE DESCRIPTION	DATE
A	New Issue	2018-9-14

1. MECHANICAL DIMENSIONS :

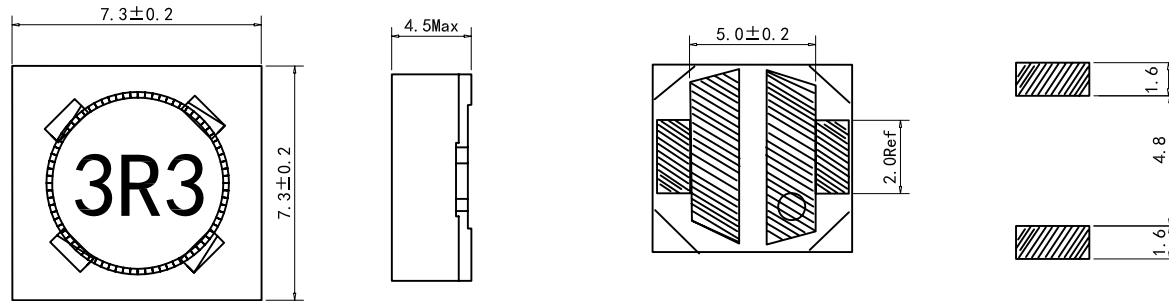

2. SCHEMATIC DIAGRAM:

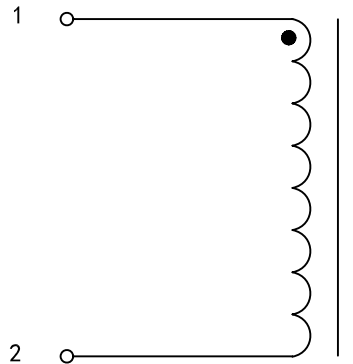

3. ELECTRICAL REQUIREMF :

TEST NOTES: (25° ±5° C)

- LX: (100KHz, 250mV) 100%
PINS: (1, 2)=3. 3±20%uH
- IDC: 3. 5A (L ≥ LOA*65%) 100%
- LL: (100KHz, 100mv) 100%
PINS: (4-6) (short1-3)=0. 06uH MAXIMUM
- OPERATING TEMPERATURE -25° C TO 80° C

TAG

泰安吉科技有限公司
TAG TECHNOLOGY CO., LTD.

A4
SIZE

TAG PART NO.:
H74R-3R3M

VENDOR PART NO.:

Drawn: 董业锦

Designed: 杨田田

Approved: Deane

Date: 2018-9-14

THESE DRAWINGS AND SPECIFICATIONS ARE THE PROPERTY OF TAG TECHNOLOGY CO., LTD. AND SHALL NOT BE REPRODUCED OR USED AS THE BASIS FOR THE MANUFACTURE OR SELL OF APPARATUSES OR DEVICES WITHOUT PERMISSION.

THIRD ANGLE
PROJECTION

DESCRIPTION:

CHOKE

UNIT mm [inch]

USED ON

SHEET 1 OF 1

REV. A