

1. MECHANICAL DIMENSIONS :

REV.	CHANGGE DESCRIPTION	DATE
A	New Issue	2013-12-20
B	线路图增加圈比	2014-12-5
C	更改线路图圈比	2014-12-8
D	高度由7.5MM改为7.8MM	2014-12-29
E	增加平整度标示	2015-10-20

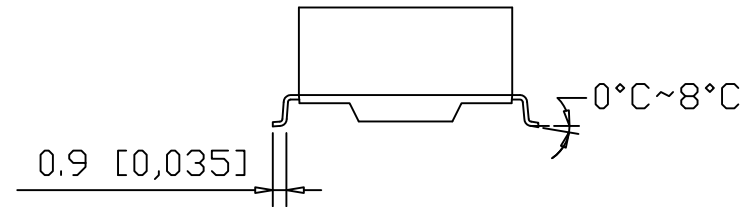
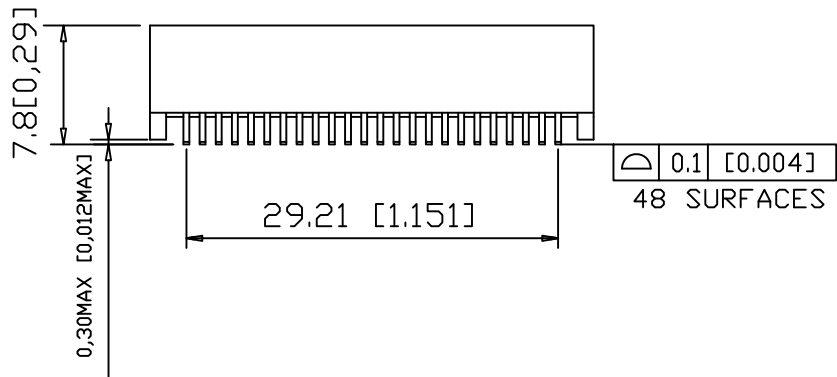
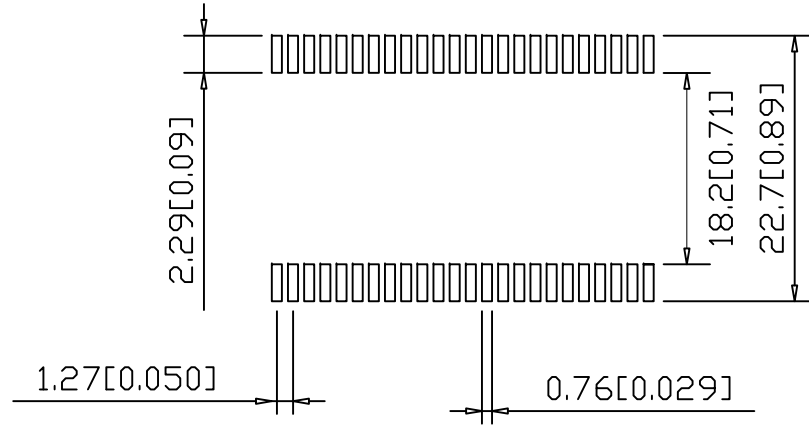
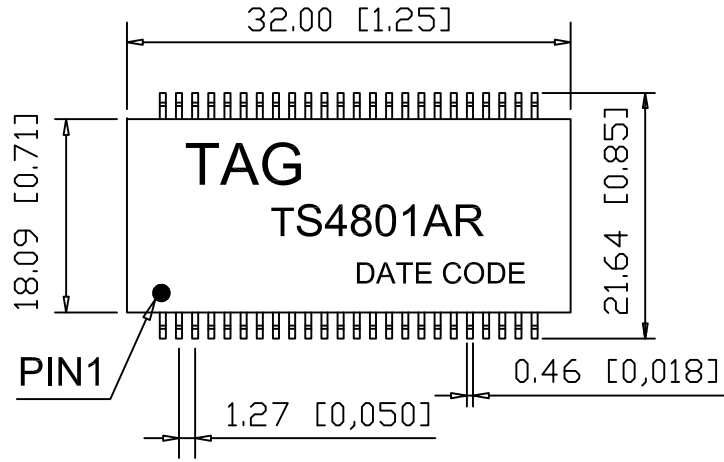

NOTE. DIMENSIONS:MM(INCHES)/UNLESS OTHERWISE SPECIFIED ALL TOLERANCES ARE ±0.25(0.010).

EKO Tech Co., Ltd.

A4
SIZE

TAG PART NO.:
TS4801AR

VENDOR PART NO.:

Drawn: 庞盛兰

Designed: 杨田田

Approved: Evan

Date: 2015-10-20

THESE DRAWINGS AND SPECIFICATIONS ARE THE PROPERTY OF TAG TECHNOLOGY CO., LTD. AND SHALL NOT BE REPRODUCED OR USED AS THE BASIS FOR THE MANUFACTURE OR SELL OF APPARATUSSES OR DEVICES WITHOUT PERMISSION.

THIRD ANGLE
PROJECTION

DESCRIPTION:
ISDN-PRI TRANSFORMER

UNIT mm[inch] USED ON

SHEET 1 OF 2

REV. E

1

2

3

4

REV.	CHANGE DESCRIPTION	DATE
A	New Issue	2013-12-20
B	线路图增加圈比	2014-12-5
C	更改线路图圈比	2014-12-8
D	高度由7.5MM改为7.8MM	2014-12-29
E	增加平整度标示	2015-10-20

2. SCHEMATIC:

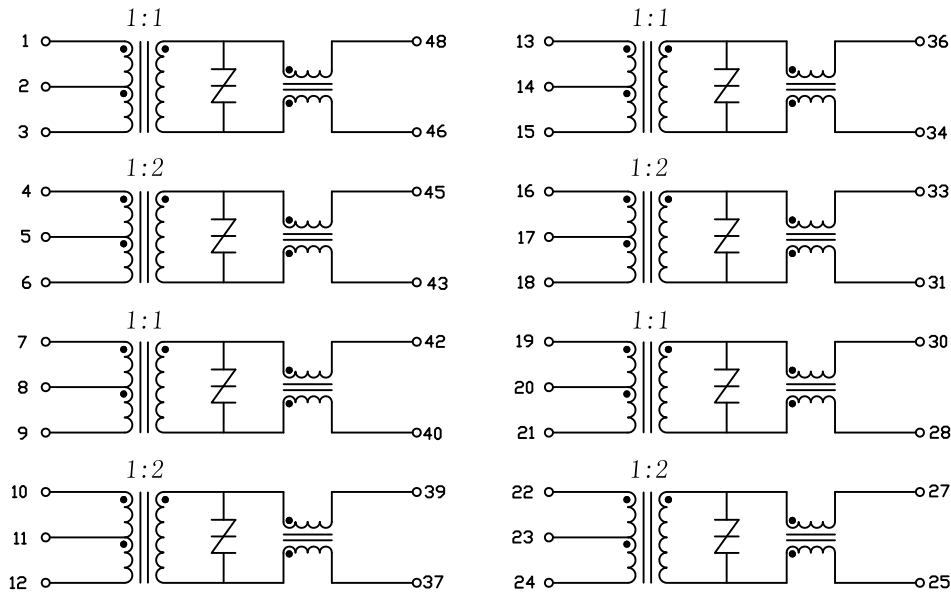

3. ELECTRICAL CHARACTERISTICS :

TEST NOTES:(25°±5°C)

- TR; 100%
PINS:(48,46):(1,3)=1:1±3%;(42,40):(7,9)=1:1±3%
PINS:(36,34):(13,15)=1:1±3%;(30,28):(19,21)=1:1±3%
PINS:(45,43):(4,6)=2:1±3%;(39,37):(10,12)=2:1±3%
PINS:(33,31):(16,18)=2:1±3%;(27,25):(22,24)=2:1±3%
- LX:(10 KHz, 0.1V); 100%
PINS:(25,27),(28,30),(31,33),(34,36)=1.2mH MINIMUM
PINS:(37,39),(40,42),(43,45),(46,48)=1.2mH MINIMUM
- LK :(100KHz, 0.1V); 100%
PINS:(1,3),(7,9)(13,15),(19,21)(short sec)=0.8 uH MAX.
PINS:(4,6),(10,12)(16,18),(22,24)(short sec)=0.8 uH MAX.
- Cw/w:
PINS:(1,3),(7,9)(13,15),(19,21)TD sec=35pF MAX
PINS:(4,6),(10,12)(16,18),(22,24)TD sec=35pF MAX
- DCR; 100%
PINS:(4,6),(10,12)(16,18),(22,24)=0.4Ω MAXIMUM
PINS:(1,3),(7,9)(13,15),(19,21)=0.8Ω MAXIMUM
PINS:(25,27),(28,30)(31,33),(34,36),(37,39),(40,42),(43,45),(46,48)=1.1Ω MAXIMUM
- HIPDT; 100%
PINS:(1,2,3)TD(48,46),(4,5,6)TD(45,43)=1500VAC FOR 60 SECONDS
PINS:(7,8,9)TD(42,40),(10,11,12)TD(39,37)=1500VAC FOR 60 SECONDS
PINS:(13,14,15)TD(36,34),(16,17,18)TD(33,31)=1500VAC FOR 60 SECONDS
PINS:(19,20,21)TD(30,28),(22,23,24)TD(27,25)=1500VAC FOR 60 SECONDS
- THYRISTOR:TISP4040L 1BJR-S
- OPERATING TEMPERATURE 0°C to 70°C
- New housing
- Extended pin length

EKO Tech Co., Ltd.

A4
SIZE

TAG PART NO.:
TS4801AR

VENDOR PART NO.:

Drawn: 庞盛兰

Designed: 杨田田

Approved: Evan

Date: 2015-10-20

THESE DRAWINGS AND SPECIFICATIONS ARE THE PROPERTY OF TAG TECHNOLOGY CO., LTD. AND SHALL NOT BE REPRODUCED OR USED AS THE BASIS FOR THE MANUFACTURE OR SELL OF APPARATUS OR DEVICES WITHOUT PERMISSION.



DESCRIPTION:

ISDN-PRI TRANSFORMER

UNIT	mm[Inch]	USED ON
SHEET	2	OF 2

REV. E

1

2

3

4